



**ГОСУДАРСТВЕННЫЕ СТАНДАРТЫ
СОЮЗА ССР**

**КАЛИБРЫ РЕЗЬБОВЫЕ
ДЛЯ МЕТРИЧЕСКОЙ РЕЗЬБЫ
КОНСТРУКЦИЯ И ОСНОВНЫЕ РАЗМЕРЫ
ГОСТ 17756-72— ГОСТ 17767-72**

Издание официальное

**ГОСУДАРСТВЕННЫЙ КОМИТЕТ СССР ПО УПРАВЛЕНИЮ
КАЧЕСТВОМ ПРОДУКЦИИ И СТАНДАРТАМ**

Москва

ГОСУДАРСТВЕННЫЕ СТАНДАРТЫ
СОЮЗА ССР

КАЛИБРЫ РЕЗЬБОВЫЕ
ДЛЯ МЕТРИЧЕСКОЙ РЕЗЬБЫ
КОНСТРУКЦИЯ И ОСНОВНЫЕ РАЗМЕРЫ
ГОСТ 17756-72 — ГОСТ 17767-72

Издание официальное

МОСКВА—1990

ГОСУДАРСТВЕННЫЙ СТАНДАРТ СОЮЗА ССР**ПРОБКИ РЕЗЬБОВЫЕ СО ВСТАВКАМИ
С ПОЛНЫМ ПРОФИЛЕМ РЕЗЬБЫ
ДИАМЕТРОМ от 1 до 100 мм**

Конструкция и основные размеры

Threaded plug-gauges with inserts with full
form of thread of diameters from 1 to 100 mm.
Design and basic dimensions**ГОСТ
17756—72**

ОКП 39 3141

Дата введения 01.07.73

1. Настоящий стандарт распространяется на пробки резьбовые для контроля метрической резьбы по ГОСТ 16093.

(Измененная редакция, Изм. № 2).

2. Конструкция и основные размеры пробок *ПР*, *У—ПР*, *КПР—ПР*, *У—НЕ*, *КНЕ—НЕ*, *КНЕ—ПР*, *КН—НЕ* должны соответствовать указанным на черт. 1 и в табл. 1.

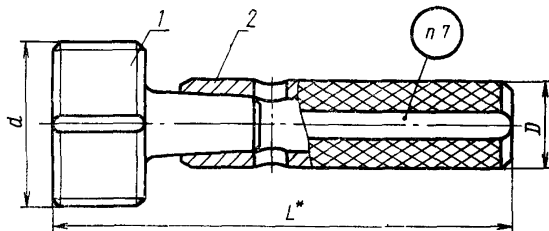

* Размер для справок.

Черт. 1

Размеры

Обозначение					
Калибры	Контрольные				
	<i>ПР</i>	<i>У—ПР</i>	<i>КПР—ПР</i>	<i>У—НЕ</i>	<i>КНЕ—НЕ</i>
8221-0001	8261-0001	8261-0310	—	—	—
8221-0002	8261-0002	8261-0311	—	—	—
8221-0003	8261-0003	8261-0312	—	—	—
8221-0004	8261-0004	8261-0313	—	—	—
8221-0005	8261-0005	8261-0314	—	—	—
8221-0006	8261-0006	8261-0315	—	—	—
8221-0007	8261-0007	8261-0316	—	—	—
8221-0008	8261-0008	8261-0317	—	—	—
8221-0009	8261-0009	8261-0318	—	—	—
8221-0010	8261-0010	8261-0319	—	—	—
8221-0011	8261-0011	8261-0320	—	—	—
8221-0012	8261-0012	8261-0321	—	—	—
8221-0013	8261-0013	8261-0322	8261-1013	8261-2013	8261-0575
8221-0014	8261-0014	8261-0323	—	—	—
8221-0015	8261-0015	8261-0324	8261-1015	8261-2015	8261-0577
8221-0016	8261-0016	8261-0325	—	—	—
8221-0017	8261-0017	8261-0326	8261-1017	8261-2017	8261-0579
8221-0018	8261-0018	8261-0327	—	—	—
8221-0019	8261-0019	8261-0328	8261-1019	8261-2019	8261-0581
8221-0020	8261-0020	8261-0329	—	—	—
8221-0021	8261-0021	8261-0330	8261-1021	8261-2021	8261-0583
8221-0022	8261-0022	8261-0331	—	—	—
8221-0023	8261-0023	8261-0332	8261-1023	8261-2023	8261-0585
8221-0024	8261-0024	8261-0333	8261-1024	8261-2024	8261-0586
8221-0025	8261-0025	8261-0334	8261-1025	8261-2025	8261-0587
8221-0026	8261-0026	8261-0335	8261-1026	8261-2026	8261-0588
8221-0027	8261-0027	8261-0336	8261-1027	8261-2027	8261-0589
8221-0028	8261-0028	8261-0337	8261-1028	8261-2028	8261-0590
8221-0029	8261-0029	8261-0338	8261-1029	8261-2029	8261-0591

Таблица 1

в мм

пробок	Применяемость						d	P	L		D	Масса, кг. не более		Дет. 1. Вста- вка (1 шт.)	Дет. 2 Ручка ГОСТ 14748 (1 шт.)
	калибры	ПР	У-ПР	КПР-ПР	У-НЕ	КНЕ-НЕ			КНЕ-ПР	КИ-НЕ		ПР; У-ПР; КПР-ПР	У-НЕ; КНЕ-НЕ; КНЕ-ПР; КИ-НЕ		
КИ-НЕ							ПР	У-ПР			КПР-ПР			У-НЕ	КНЕ-НЕ
—							1,0	0,25							
—								0,20							
—							1,1	0,25							
—								0,20							
—							1,2	0,25							
—								0,20							
—								0,30	53	—		0,0117	—		
—							1,4	0,20							
—								0,35							
—							1,6	0,20							
—								0,35							
—							1,8	0,20							
8261-3013							2,0	0,40		52,0			0,0118		
—								0,25		—	6		—		
8261-3015							2,2	0,45		52,0		0,0118	0,0118		8054-0011
—								0,25		—			—		
8261-3017							2,5	0,45	54	52,0			0,0118		
—								0,35		—			—		
8261-3019							3,0	0,50		52,0			0,0110		
—								0,35		—		0,0110	—		
8261-3021							3,5	0,60		52,5			0,0110		
—								0,35		—			—		
8261-3023							4,0	0,70		—			—		
8261-3024								0,50	55	52,5			—		
8261-3025								0,75		—			—		
8261-3026							4,5	0,50		—		0,0114	0,0112		
8261-3027								0,80	55	53,0			—		
8261-3028							5,0	0,50		—			—		
8261-3029							5,5	0,50	62	60,0	8	0,0260	0,0255		8054-0012

Обозначение дет. 1 см. табл. 2

Размеры

Обозначение					
Калибры	Контрольные				
	<i>ПР</i>	<i>У—ПР</i>	<i>КПР—ПР</i>	<i>У—НЕ</i>	<i>КНЕ—НЕ</i>
8221-0030	8261-0030	8261-0339	8261-1030	8261-2030	8261-0592
8221-0031	8261-0031	8261-0340	8261-1031	8261-2031	8261-0593
8221-0032	8261-0032	8261-0341	8261-1032	8261-2032	8261-0594
8221-0033	8261-0033	8261-0342	8261-1033	8261-2033	8261-0595
8221-0034	8261-0034	8261-0343	8261-1034	8261-2034	8261-0596
8221-0035	8261-0035	8261-0344	8261-1035	8261-2035	8261-0597
8221-0036	8261-0036	8261-0345	8261-1036	8261-2036	8261-0598
8221-0037	8261-0037	8261-0346	8261-1037	8261-2037	8261-0599
8221-0038	8261-0038	8261-0347	8261-1038	8261-2038	8261-0600
8221-0039	8261-0039	8261-0348	8261-1039	8261-2039	8261-0601
8221-0040	8261-0040	8261-0349	8261-1040	8261-2040	8261-0602
8221-0041	8261-0041	8261-0350	8261-1041	8261-2041	8261-0603
8221-0042	8261-0042	8261-0351	8261-1042	8261-2042	8261-0604
8221-0043	8261-0043	8261-0352	8261-1043	8261-2043	8261-0605
8221-0044	8261-0044	8261-0353	8261-1044	8261-2044	8261-0606
8221-0045	8261-0045	8261-0354	8261-1045	8261-2045	8261-0607
8221-0046	8261-0046	8261-0355	8261-1046	8261-2046	8261-0608
8221-0047	8261-0047	8261-0356	8261-1047	8261-2047	8261-0609
8221-0048	8261-0048	8261-0357	8261-1048	8261-2048	8261-0610
8221-0049	8261-0049	8261-0358	8261-1049	8261-2049	8261-0611
8221-0050	8261-0050	8261-0359	8261-1050	8261-2050	8261-0612
8221-0051	8261-0051	8261-0360	8261-1051	8261-2051	8261-0613
8221-0052	8261-0052	8261-0361	8261-1052	8261-2052	8261-0614
8221-0053	8261-0053	8261-0362	8261-1053	8261-2053	8261-0615
8221-0054	8261-0054	8261-0363	8261-1054	8261-2054	8261-0616
8221-0055	8261-0055	8261-0364	8261-1055	8261-2055	8261-0617
8221-0056	8261-0056	8261-0365	8261-1056	8261-2056	8261-0618
8221-0057	8261-0057	8261-0366	8261-1057	8261-2057	8261-0619
8221-0058	8261-0058	8261-0367	8261-1058	8261-2058	8261-0620

Продолжение табл. 1

Пробок	Применяемость						d	P	L			D	Масса, кг, не более		Дет. 1 Вставка (1 шт)	Дет. 2. Ручка ГОСТ 14748 (1 шт)	Обозначение деталей	
	Валыбы	ПР	У-ПР	КПР-ПР	У-НЕ	КНЕ-НЕ			КНЕ-ПР	КИ-НЕ	ПР; У-ПР; КПР-ПР		У-НЕ; КНЕ-НЕ; КНЕ-ПР; КИ-НЕ	ПР; У-ПР; КПР-ПР				У-НЕ; КНЕ-НЕ; КНЕ-ПР; КИ-НЕ
8261-3030								1,00	64	61,0								
8261-3031							6,0	0,75	64	61,0		0,0260						
8261-3032								0,50	62	60,0			0,0255					
8261-3033								1,00	64	61,0				0,0265				
8261-3034							7,0	0,75	64	61,0								
8261-3035								0,50	62	60,0			0,0260					
8261-3036								1,25	66	62,0				0,0285				
8261-3037							8,0	1,00	66	61,0					0,0270			
8261-3038								0,75	64	61,0		8,0	0,0275				8054-0012	
8261-3039								0,50	64	61,0				0,0265				
8261-3040								1,25	66	62,0				0,0295	0,0275			
8261-3041							9,0	1,00	66	61,0								
8261-3042								0,75	64	61				0,0285	0,0265			
8261-3043								0,50	64	61								
8261-3044								1,50	68	64								
8261-3045								1,25	68	63			0,032	0,030				
8261-3046							10	1,00	66	62								
8261-3047								0,75	64	61				0,029	0,028			
8261-3048								0,50	64	61								
8261-3049								1,50	77	73				0,036	0,033			
8261-3050							11	1,00	75	71								
8261-3051								0,75	73	70				0,033	0,032			
8261-3052								0,50	73	70							8054-0013	
8261-3053								1,75	80	74	10							
8261-3054								1,50	79	73			0,040	0,035				
8261-3055							12	1,25	77	72								
8261-3056								1,00	75	71								
8261-3057								0,75	75	70			0,037	0,032				
8261-3058								0,50	73	70								

Размеры

Обозначение

Калибры	Контрольные				
	У—ПР	КПР—ПР	У—НЕ	КНЕ—НЕ	КНЕ—ПР
8221-0059	8261-0059	8261-0368	8261-1059	8261-2059	8261-0621
8221-0060	8261-0060	8261-0369	8261-1060	8261-2060	8261-0622
8221-0061	8261-0061	8261-0370	8261-1061	8261-2061	8261-0623
8221-0062	8261-0062	8261-0371	8261-1062	8261-2062	8261-0624
8221-0063	8261-0063	8261-0372	8261-1063	8261-2063	8261-0625
8221-0064	8261-0064	8261-0373	8261-1064	8261-2064	8261-0626
8221-0065	8261-0065	8261-0374	8261-1065	8261-2065	8261-0627
8221-0066	8261-0066	8261-0375	8261-1066	8261-2066	8261-0628
8221-0067	8261-0067	8261-0376	8261-1067	8261-2067	8261-0629
8221-0068	8261-0068	8261-0377	8261-1068	8261-2068	8261-0630
8221-0069	8261-0069	8261-0378	8261-1069	8261-2069	8261-0631
8221-0070	8261-0070	8261-0379	8261-1070	8261-2070	8261-0632
8221-0071	8261-0071	8261-0380	8261-1071	8261-2071	8261-0633
8221-0072	8261-0072	8261-0381	8261-1072	8261-2072	8261-0634
8221-0073	8261-0073	8261-0382	8261-1073	8261-2073	8261-0635
8221-0074	8261-0074	8261-0383	8261-1074	8261-2074	8261-0636
8221-0075	8261-0075	8261-0384	8261-1075	8261-2075	8261-0637
8221-0076	8261-0076	8261-0385	8261-1076	8261-2076	8261-0638
8221-0077	8261-0077	8261-0386	8261-1077	8261-2077	8261-0639
8221-0078	8261-0078	8261-0387	8261-1078	8261-2078	8261-0640
8221-0079	8261-0079	8261-0388	8261-1079	8261-2079	8261-0641
8221-0080	8261-0080	8261-0389	8261-1080	8261-2080	8261-0642
8221-0081	8261-0081	8261-0390	8261-1081	8261-2081	8261-0643
8221-0082	8261-0082	8261-0391	8261-1082	8261-2082	8261-0644
8221-0083	8261-0083	8261-0392	8261-1083	8261-2083	8261-0645
8221-0084	8261-0084	8261-0393	8261-1084	8261-2084	8261-0646
8221-0085	8261-0085	8261-0394	8261-1085	8261-2085	8261-0647
8221-0086	8261-0086	8261-0395	8261-1086	8261-2086	8261-0648
8221-0087	8261-0087	8261-0396	8261-1087	8261-2087	8261-0649

в мм

пробок	Применяемость						d	P	L		D	Масса, кг, не более		Дет. 1. Вста- вка (1 шт.)	Дет. 2. Ручка ГОСТ 14748 (1 шт.)
	калибры	ПР	У-ПР	КПР-ПР	У-НЕ	КНЕ-НЕ			КНЕ-ПР	КИ-НЕ		ПР, У-ПР; КПР-ПР	У-НЕ; КНЕ-НЕ; КНЕ-ПР, КИ-НЕ		
КИ-НЕ							ПР	У-ПР			КПР-ПР			У-НЕ	КНЕ-НЕ
8261-3059								2,00	81	75		0,047	0,040	8054-0013	
8261-3060								1,50	79	73					
8261-3061							14	1,25	77	72	10	0,045	0,038		
8261-3062								1,00	77	71					
8261-3063								0,75	75	70		0,040	0,034		
8261-3064								0,50	73	70					
8261-3065							15	1,50	90	84		0,074	0,066		
8261-3066								1,00	88	83					
8261-3067								2,00	92	86					
8261-3068								1,50	90	84		0,082	0,071		
8261-3069							16	1,00	88	83					
8261-3070								0,75	86	82		0,070	0,066		
8261-3071								0,50	84	81					
8261-3072							17	1,50	90	84	13	0,082	0,072		
8261-3073								1,00	88	83					
8261-3074								2,50	96	88					
8261-3075								2,00	94	86		0,096	0,082		
8261-3076								1,50	90	84					
8261-3077							18	1,00	88	83					
8261-3078								0,75	86	82		0,082	0,072		
8261-3079								0,50	86	82					
8261-3080								2,50	107	99		0,150	0,129		
8261-3081								2,00	105	97					
8261-3082							20	1,50	101	95					
8261-3083								1,00	99	94,0	16	0,134	0,118		
8261-3084								0,75	97	93,0		0,127	0,122		
8261-3085								0,50	97	93,0					
8261-3086								2,50	107	99,0		0,162	0,137		
8261-3087							22	2,00	105	97,0					

Обозначение дет. 1 см. табл. 2

Размеры

Обозначение

Калибры	Контрольные				
	У—ПР	КПР—ПР	У—НЕ	КНЕ,—НЕ	КНЕ—ПР
8221-0088	8261-0088	8261-0397	8261-1088	8261-2088	8261-0650
8221-0089	8261-0089	8261-0398	8261-1089	8261-2089	8261-0651
8221-0090	8261-0090	8261-0399	8261-1090	8261-2090	8261-0652
8221-0091	8261-0091	8261-0400	8261-1091	8261-2091	8261-0653
8221-0092	8261-0092	8261-0401	8261-1092	8261-2092	8261-0654
8221-0093	8261-0093	8261-0402	8261-1093	8261-2093	8261-0655
8221-0094	8261-0094	8261-0403	8261-1094	8261-2094	8261-0656
8221-0095	8261-0095	8261-0404	8261-1095	8261-2095	8261-0657
8221-0096	8261-0096	8261-0405	8261-1096	8261-2096	8261-0658
8221-0097	8261-0097	8261-0406	8261-1097	8261-2097	8261-0659
8221-0098	8261-0098	8261-0407	8261-1098	8261-2098	8261-0660
8221-0099	8261-0099	8261-0408	8261-1099	8261-2099	8261-0661
8221-0100	8261-0100	8261-0409	8261-1100	8261-2100	8261-0662
8221-0101	8261-0101	8261-0410	8261-1101	8261-2101	8261-0663
8221-0102	8261-0102	8261-0411	8261-1102	8261-2102	8261-0664
8221-0103	8261-0103	8261-0412	8261-1103	8261-2103	8261-0665
8221-0104	8261-0104	8261-0413	8261-1104	8261-2104	8261-0666
8221-0105	8261-0105	8261-0414	8261-1105	8261-2105	8261-0667
8221-0106	8261-0106	8261-0415	8261-1106	8261-2106	8261-0668
8221-0107	8261-0107	8261-0416	8261-1107	8261-2107	8261-0669
8221-0108	8261-0108	8261-0417	8261-1108	8261-2108	8261-0670
8221-0109	8261-0109	8261-0418	8261-1109	8261-2109	8261-0671
8221-0110	8261-0110	8261-0419	8261-1110	8261-2110	8261-0672
8221-0111	8261-0111	8261-0420	8261-1111	8261-2111	8261-0673
8221-0112	8261-0112	8261-0421	8261-1112	8261-2112	8261-0674
8221-0113	8261-0113	8261-0422	8261-1113	8261-2113	8261-0675
8221-0114	8261-0114	8261-0423	8261-1114	8261-2114	8261-0676
8221-0115	8261-0115	8261-0424	8261-1115	8261-2115	8261-0677
8221-0116	8261-0116	8261-0425	8261-1116	8261-2116	8261-0678

Продолжение табл. 1

В мм

пробок	Применяемость						d	P	L		D	Масса кг. не более		Дет. 1. Вста- вка (1 шт.)	Дет. 2. Ручка ГОСТ 14748 (1 шт.)													
	калибры	ПР	У-ПР	КПР-ПР	У-НЕ	КНЕ-НЕ			КНЕ-ПР	КИ-НЕ		ПР, У-ПР; КПР-ПР	У-НЕ; КНЕ-НЕ; КНЕ-ПР; КИ-НЕ			ПР, У-ПР; КПР-ПР	У-НЕ; КНЕ-НЕ; КНЕ-ПР; КИ-НЕ	Обозначение деталей										
КИ-НЕ																												
8261-3088								1,50	101	95,0		0,143	0,122	8054-0015														
8261-3089							22	1,00	99	94,0					8054-0015													
8261-3090								0,75	97	93,0						8054-0015												
8261-3091								0,50	97	93,0		0,132	0,117				8054-0015											
8261-3092								3,00	112	101,0	16	0,193	0,151					8054-0015										
8261-3093								2,00	105	97,0		0,165							8054-0015									
8261-3094							24	1,50	103	95,0										8054-0015								
8261-3095								1,00	101	94,5		0,162	0,132								8054-0015							
8261-3096								0,75	99	94,0												8054-0015						
8261-3097								2,00	116	108,0		0,227											8054-0015					
8261-3098							25	1,50	114	106,0		0,220	0,190											8054-0015				
8261-3099								1,00	112	105,5															8054-0015			
8261-3100							26	1,50	114	106,0		0,225														8054-0015		
8261-3101								3,00	123	112,0		0,275	0,220														8054-0015	
8261-3102								2,00	116	108,0		0,242	0,203															8054-0015
8261-3103							27	1,50	114	106,0		0,230																
8261-3104								1,00	112	105,5				8054-0015														
8261-3105								0,75	110	105,0		0,220	0,190		8054-0015													
8261-3106								2,00	116	108,0	20					8054-0015												
8261-3107							28	1,50	114	107,0		0,245	0,210				8054-0015											
8261-3108								1,00	112	105,5		0,225	0,190					8054-0015										
8261-3109								3,50	126	114,0		0,32	0,25						8054-0015									
8261-3110								3,00	126	112,0										8054-0015								
8261-3111								2,00	118	100,0		0,27	0,22								8054-0015							
8261-3112							30	1,50	116	107,0												8054-0015						
8261-3113								1,00	114	106,5		0,25	0,20										8054-0015					
8261-3114								0,75	112	106,0														8054-0015				
8261-3115							32	2,00	119	111,0		0,39	0,31												8054-0017			
8261-3116								1,50	117	108,0																8054-0017		

Размеры

Обозначение					
Калібры	Контрольные				
	У—ПР	КПР—ПР	У—НЕ	КНЕ —НЕ	КНЕ—ПР
8221-0117	8261-0117	8261-0426	8261-1117	8261-2117	8261-0679
8221-0118	8261-0118	8261-0427	8261-1118	8261-2118	8261-0680
8221-0119	8261-0119	8261-0428	8261-1119	8261-2119	8261-0681
8221-0120	8261-0120	8261-0429	8261-1120	8261-2120	8261-0682
8221-0121	8261-0121	8261-0430	8261-1121	8261-2121	8261-0683
8221-0122	8261-0122	8261-0431	8261-1122	8261-2122	8261-0684
8221-0123	8261-0123	8261-0432	8261-1123	8261-2123	8261-0685
8221-0124	8261-0124	8261-0433	8261-1124	8261-2124	8261-0686
8221-0125	8261-0125	8261-0434	8261-1125	8261-2125	8261-0687
8221-0126	8261-0126	8261-0435	8261-1126	8261-2126	8261-0688
8221-0127	8261-0127	8261-0436	8261-1127	8261-2127	8261-0689
8221-0128	8261-0128	8261-0437	8261-1128	8261-2128	8261-0690
8221-0129	8261-0129	8261-0438	8261-1129	8261-2129	8261-0691
8221-0130	8261-0130	8261-0439	8261-1130	8261-2130	8261-0692
8221-0131	8261-0131	8261-0440	8261-1131	8261-2131	8261-0693
8221-0132	8261-0132	8261 0441	8261-1132	8261-2132	8261-0694
8221-0133	8261-0133	8261-0442	8261-1133	8261-2133	8261-0695
8221-0134	8261-0134	8261-0443	8261-1134	8261-2134	8261-0696
8221-0135	8261-0135	8261-0444	8261-1135	8261-2135	8261-0697
8221-0136	8261-0136	8261-0445	8261-1136	8261-2136	8261-0698
8221-0137	8261-0137	8261-0446	8261-1137	8261-2137	8261-0699
8221-0138	8261-0138	8261-0447	8261-1138	8261-2138	8261-0700
8221-0139	8261-0139	8261-0448	8261-1139	8261-2139	8261-0701
8221-0140	8261-0140	8261-0449	8261-1140	8261-2140	8261-0702
8221-0141	8261-0141	8261-0450	8261-1141	8261-2141	8261-0703
8221-0142	8261-0142	8261-0451	8261-1142	8261-2142	8261-0704
8221-0143	8261-0143	8261-0452	8261-1143	8261-2143	8261-0705
8221-0144	8261-0144	8261-0453	8261-1144	8261-2144	8261-0706
8221-0145	8261-0145	8261-0454	8261-1145	8261-2145	8261-0707

Продолжение табл. 1

В мм

пробок	Применяемость						d	P	L		D	Масса, кг. не более		Дет. 1. Вста- вка (1 шт.)	Дет. 2. Ручка ГОСТ 14748 (1 шт.)
	калибры	ПР	У-ПР	КПР-ПР	У-НЕ	КНЕ-НЕ			КНЕ-ПР	КИ-НЕ		ПР, У-ПР; КПР-ПР	У-НЕ; КНЕ-НЕ; КНЕ-ПР; КИ-НЕ		
КИ-НЕ							ПР	У-ПР			КПР-ПР			У-НЕ	КНЕ-НЕ
8261-3117								3,50	127	115,0		0,45	0,36		
8261-3118								3,00	127	113,0					
8261-3119							33	2,00	119	111,0		0,39	0,34		
8261-3120								1,50	117	108,0					
8261-3121								1,00	115	107,5		0,36	0,31		
8261-3122								0,75	113	107,0					
8261-3123							35	1,50	117	109,5		0,37	0,34		
8261-3124								4,00	131	118,0		0,52	0,39		
8261-3125								3,00	127	113,0		0,48	0,36		
8261-3126							36	2,00	119	110,0	24	0,41	0,34		
8261-3127								1,50	117	109,5		0,40	0,33		
8261-3128								1,00	115	109,0					
8261-3129							38	1,50	117	109,5		0,41	0,34		
8261-3130								4,00	131	118,0		0,57	0,44		
8261-3131								3,00	127	113,0		0,52	0,38		
8261-3132							39	2,00	119	110,0					
8261-3133								1,50	117	109,5		0,45	0,35		
8261-3134								1,00	115	109,0					
8261-3135								3,00	127	113,0		0,55			
8261-3136							40	2,00	119	111,0		0,46	0,39		
8261-3137								1,50	117	110,0					
8261-3138								4,50	148	131,0		0,79	0,59		
8261-3139								4,00	146	128,0					
8261-3140							42	3,00	138	124,0		0,68	0,54		
8261-3141								2,00	132	122,0	28				
8261-3142								1,50	130	121,0		0,60	0,50		
8261-3143								1,00	128	120,0					
8261-3144							45	4,50	148	131,0		0,86	0,62		
8261-3145								4,00	146	128,0					

Обозначение дет. 1 см. табл. 2

8054-0017

8054-0018

Обозначение					
Калибры	Контрольные				
	<i>ПР</i>	<i>У—ПР</i>	<i>КПР—ПР</i>	<i>У—НЕ</i>	<i>КНЕ—НЕ</i>
8221-0146	8261-0146	8261-0455	8261-1146	8261-2146	8261-0708
8221-0147	8261-0147	8261-0456	8261-1147	8261-2147	8261-0709
8221-0148	8261-0148	8261-0457	8261-1148	8261-2148	8261-0710
8221-0149	8261-0149	8261-0458	8261-1149	8261-2149	8261-0711
8221-0150	8261-0150	8261-0459	8261-1150	8261-2150	8261-0712
8221-0151	8261-0151	8261-0460	8261-1151	8261-2151	8261-0713
8221-0152	8261-0152	8261-0461	8261-1152	8261-2152	8261-0714
8221-0153	8261-0153	8261-0462	8261-1153	8261-2153	8261-0715
8221-0154	8261-0154	8261-0463	8261-1154	8261-2154	8261-0716
8221-0155	8261-0155	8261-0464	8261-1155	8261-2155	8261-0717
8221-0156	8261-0156	8261-0465	8261-1156	8261-2156	8261-0718
8221-0157	8261-0157	8261-0466	8261-1157	8261-2157	8261-0719
8221-0158	8261-0158	8261-0467	8261-1158	8261-2158	8261-0720
8221-0159	8261-0159	8261-0468	8261-1159	8261-2159	8261-0721
8221-0160	8261-0160	8261-0469	8261-1160	8261-2160	8261-0722
8221-0161	8261-0161	8261-0470	8261-1161	8261-2161	8261-0723
8221-0162	8261-0162	8261-0471	8261-1162	8261-2162	8261-0724
8221-0163	8261-0163	8261-0472	8261-1163	8261-2163	8261-0725
8221-0164	8261-0164	8261-0473	8261-1164	8261-2164	8261-0726
8221-0165	8261-0165	8261-0474	8261-1165	8261-2165	8261-0727
8221-0166	8261-0166	8261-0475	8261-1166	8261-2166	8261-0728
8221-0167	8261-0167	8261-0476	8261-1167	8261-2167	8261-0729
8221-0168	8261-0168	8261-0477	8261-1168	8261-2168	8261-0730
8221-0169	8261-0169	8261-0478	8261-1169	8261-2169	8261-0731
8221-0170	8261-0170	8261-0479	8261-1170	8261-2170	8261-0732
8221-0171	8261-0171	8261-0480	8261-1171	8261-2171	8261-0733
8221-0172	8261-0172	8261-0481	8261-1172	8261-2172	8261-0734
8221-0173	8261-0173	8261-0482	8261-1173	8261-2173	8261-0735
8221-0174	8261-0174	8261-0483	8261-1174	8261-2174	8261-0736

В мм

пробок	Применяемость						d	P	L			Масса, кг, не более		Дет. 1. Вста- вка (1 шт.)	Дет. 2. Ручка ГОСТ 14748 (1 шт.)
	калибры	ПР	У-ПР	КПР-ПР	У-НЕ	КНЕ-НЕ			КНЕ-ПР	КИ-НЕ	ПР У-ПР, КПР-ПР	У-НЕ, КНЕ-НЕ, КНЕ-ПР; КИ-НЕ	D		
КИ-НЕ															
8261-3146								3,00	138	125		0,72	0,55		
8261-3147							45	2,00	132	122		0,64	0,51		
8261-3148								1,50	130	121					
8261-3149								1,00	128	120		0,60	0,48		
8261-3150								5,00	152	135		1,00	0,70		
8261-3151								4,00	146	130		0,89	0,63		
8261-3152							48	3,00	138	125		0,78	0,57		
8261-3153								2,00	132	122					
8261-3154								1,50	130	121		0,68	0,53		
8261-3155								1,00	128	120					
8261-3156								3,00	138	125		0,81	0,59		
8261 3157							50	2,00	132	122		0,71	0,53		
8261-3158								1,50	130	121	28				
8261-3159								5,00	152	135		1,11	0,77		
8261-3160								4,00	146	130		0,98	0,70		
8261-3161							52	3,00	138	125		0,86			
8261 3162								2,00	132	122			0,61		
8261 3163								1,50	130	121		0,74			
8261 3164								1,00	128	120					
8261-3165								4,0	146	130		1,07	0,75		
8261-3166								3,0	138	125		0,91			
8261-3167							55	2,0	132	124		0,89	0,65		
8261-3168								1,5	130	123					
8261 3169								5,5	160	138		1,39	0,93		
8261 3170								4,0	146	130		1,08	0,75		
8261-3171							56	3,0	138	125		0,93			
8261-3172								2,0	132	124		0,81	0,66		
8261-3173								1,5	130	123					
8261 3174								1,0	128	122		0,76	0,62		

Обозначение дет. 1 см табл 2

8054-0018

Размеры

Обозначение					
Калибры	Контрольные				
	<i>У—ПР</i>	<i>КПР—ПР</i>	<i>У—НЕ</i>	<i>КНЕ—НЕ</i>	<i>КНЕ—ПР</i>
8221-0175	8261-0175	8261-0484	8261-1175	8261-2175	8261-0737
8221-0176	8261-0176	8261-0485	8261-1176	8261-2176	8261-0738
8221-0177	8261-0177	8261-0486	8261-1177	8261-2177	8261-0739
8221-0178	8261-0178	8261-0487	8261-1178	8261-2178	8261-0740
8221-0179	8261-0179	8261-0488	8261-1179	8261-2179	8261-0741
8221-0180	8261-0180	8261-0489	8261-1180	8261-2180	8261-0742
8221-0181	8261-0181	8261-0490	8261-1181	8261-2181	8261-0743
8221-0182	8261-0182	8261-0491	8261-1182	8261-2182	8261-0744
8221-0183	8261-0183	8261-0492	8261-1183	8261-2183	8261-0745
8221-0184	8261-0184	8261-0493	8261-1184	8261-2184	8261-0746
8221-0185	8261-0185	8261-0494	8261-1185	8261-2185	8261-0747
8221-0186	8261-0186	8261-0495	8261-1186	8261-2186	8261-0748
8221-0187	8261-0187	8261-0496	8261-1187	8261-2187	8261-0749
8221-0188	8261-0188	8261-0497	8261-1188	8261-2188	8261-0750
8221-0189	8261-0189	8261-0498	8261-1189	8261-2189	8261-0751
8221-0190	8261-0190	8261-0499	8261-1190	8261-2190	8261-0752
8221-0191	8261-0191	8261-0500	8261-1191	8261-2191	8261-0753
8221-0192	8261-0192	8261-0501	8261-1192	8261-2192	8261-0754
8221-0193	8261-0193	8261-0502	8261-1193	8261-2193	8261-0755
8221-0194	8261-0194	8261-0503	8261-1194	8261-2194	8261-0756
8221-0195	8261-0195	8261 0504	8261-1195	8261-2195	8261-0757
8221-0196	8261-0196	8261-0505	8261-1196	8261-2196	8261-0758
8221-0197	8261-0197	8261 0506	8261-1197	8261-2197	8261-0759
8221-0198	8261-0198	8261-0507	8261-1198	8261-2198	8261-0760
8221-0199	8261-0199	8261-0508	8261-1199	8261-2199	8261-0761
8221-0200	8261-0200	8261-0509	8261-1200	8261-2200	8261-0762
8221-0201	8261-0201	8261 0510	8261-1201	8261-2201	8261-0763
8221-0202	8261-0202	8261-0511	8261-1202	8261-2202	8261-0764

Продолжение табл. 1

В мм

пробок	Применяемость						d	P	L			D	Масса, кг, не более		Дет. 1. Вста- вка (1 шт.)	Дет. 2. Ручка ГОСТ 14748 (1 шт.)
	калибры	ПР	У--ПР	КПР--ПР	У--НЕ	КНЕ--НЕ			КНЕ--ПР	КИ--НЕ	ПР, У--ПР; КПР--ПР		У--НЕ; КНЕ--НЕ; КНЕ--ПР; КИ--НЕ	ПР, У--ПР, КПР--ПР		
8261-3175								4,0	146	130		1,15	0,79			
8261-3176							58	3,0	138	125		0,98				
8261-3177								2,0	132	124		0,86	0,66			
8261 3178								1,5	130	123						
8261-3179								5,5	160	138		1,56	1,01			
8261-3180								4,0	146	130		1,21	0,82			
8261-3181							60	3,0	138	125		1,02				
8261-3182								2,0	132	124		0,88	0,66			
8261-3183								1,5	130	123						
8261-3184								1,0	128	122		0,78	0,64			
8261-3185								4 0	146	130		1,26	0,85			
8261-3186							62	3,0	138	125		1,06				
8261-3187								2,0	135	124		0,99	0,75			
8261-3188								1,5	132	123	28					
8261-3189								6,0	166	140		1,89	1,12			
8261-3190								4,0	146	130		1,31	0,89			
8261-3191							64	3,0	138	125		1,12				
8261-3192								2,0	135	124		1,04				
8261-3193								1,5	132	123		0,95	0,76			
8261-3194								1,0	128	122						
8261-3195								4,0	146	130		1,34	0,91			
8261-3196							65	3,0	138	125		1,14				
8261-3197								2,0	135	124		1,06	0,80			
8261-3198								1,5	132	123						
8261-3199								6,0	166	140		2,06	1,27			
8261-3200								4,0	146	130		1,46	0,96			
8261-3201							68	3,0	138	125		1,22				
8261-3202								2,0	135	124		1,12	0,81			

Обозначение дет. 1 см. табл. 2

8054-0018

Размеры

Обозначение					
Калибры	Контрольные				
	<i>У—ПР</i>	<i>КПР—ПР</i>	<i>У—НЕ</i>	<i>КНЕ—НЕ</i>	<i>КНЕ—ПР</i>
8221-0203	8261-0203	8261-0512	8261-1203	8261-2203	8261-0765
8221-0204	8261-0204	8261-0513	8261-1204	8261-2204	8261-0766
8221-0205	8261-0205	8261-0514	8261-1205	8261-2205	8261-0767
8221-0206	8261-0206	8261-0515	8261-1206	8261-2206	8261-0768
8221-0207	8261-0207	8261-0516	8261-1207	8261-2207	8261-0769
8221-0208	8261-0208	8261-0517	8261-1208	8261-2208	8261-0770
8221-0209	8261-0209	8261-0518	8261-1209	8261-2209	8261-0771
8221-0210	8261-0210	8261-0519	8261-1210	8261-2210	8261-0772
8221-0211	8261-0211	8261-0520	8261-1211	8261-2211	8261-0773
8221-0212	8261-0212	8261-0521	8261-1212	8261-2212	8261-0774
8221-0213	8261-0213	8261-0522	8261-1213	8261-2213	8261-0775
8221-0214	8261-0214	8261-0523	8261-1214	8261-2214	8261-0776
8221-0215	8261-0215	8261-0524	8261-1215	8261-2215	8261-0777
8221-0216	8261-0216	8261-0525	8261-1216	8261-2216	8261-0778
8221-0217	8261-0217	8261-0526	8261-1217	8261-2217	8261-0779
8221-0218	8261-0218	8261-0527	8261-1218	8261-2218	8261-0780
8221-0219	8261-0219	8261-0528	8261-1219	8261-2219	8261-0781
8221-0220	8261-0220	8261-0529	8261-1220	8261-2220	8261-0782
8221-0221	8261-0221	8261-0530	8261-1221	8261-2221	8261-0783
8221-0222	8261-0222	8261-0531	8261-1222	8261-2222	8261-0784
8221-0223	8261-0223	8261-0532	8261-1223	8261-2223	8261-0785
8221-0224	8261-0224	8261-0533	8261-1224	8261-2224	8261-0786
8221-0225	8261-0225	8261-0534	8261-1225	8261-2225	8261-0787
8221-0226	8261-0226	8261-0535	8261-1226	8261-2226	8261-0788
8221-0227	8261-0227	8261-0536	8261-1227	8261-2227	8261-0789
8221-0228	8261-0228	8261-0537	8261-1228	8261-2228	8261-0790
8221-0229	8261-0229	8261-0538	8261-1229	8261-2229	8261-0791
8221-0230	8261-0230	8261-0539	8261-1230	8261-2230	8261-0792

Продолжение табл. 1

в мм		Применяемость						d	L			D	Масса, кг, не более		Дет. 1. Вставка (1 шт.)	Дет. 2. Ручка ГОСТ 14748 (1 шт.)
пробок	калибры	ПР	У-ПР	КПР-ПР	У-НЕ	КНЕ-НЕ	КНЕ-ПР		КИ-НЕ	ПР; У-ПР; КПР-ПР	У-НЕ; КНЕ-НЕ; КНЕ-ПР; КИ-НЕ		ПР; У-ПР; КПР-ПР	У-НЕ; КНЕ-НЕ; КНЕ-ПР; КИ-НЕ		
	КИ-НЕ							68	1,5	132	123	28	1,03	0,76	8054-0018	Обозначение деталей
									1,0	128	122					
								70	6,0	166	140		2,20	1,33		
										4,0	148	130		1,60		
									3,0	140	126		1,33			
									2,0	135	125			0,88		
									1,5	132	124		1,17			
								72	6,0	166	140		2,41	1,53		
										4,0	148	130		1,80		
									3,0	140	126		1,53			
									2,0	135	125					
									1,5	132	124		1,35	1,04		
									1,0	130	123		1,18			
								75	4,0	148	130		1,92	1,24		
										3,0	140	126		1,61		
									2,0	135	125			1,09		
									1,5	132	124		1,42			
								76	6,0	166	140	32	2,66	1,64		
										4,0	148		130			
									3,0	140	126		1,65			
									2,0	135	125			1,10		
									1,5	132	124		1,45			
									1,0	130	123		1,27	1,04		
								78	2,0	135	125		1,50	1,10		
										6,0	166	140		2,86	1,77	
									4,0	148	130		2,12	1,34		
								80	3,0	140	126		1,77			
										2,0	135	125		1,62	1,17	

Обозначение дет. 1 см. табл. 2

8054-0019

Размеры

Обозначение					
Калибры	Контрольные				
	<i>У—ПР</i>	<i>КПР—ПР</i>	<i>У—НЕ</i>	<i>КНЕ - НЕ</i>	<i>КНЕ—ПР</i>
8221-0231	8261-0231	8261-0540	8261-1231	8261-2231	8261-0793
8221-0232	8261-0232	8261-0541	8261-1232	8261-2232	8261-0794
8221-0233	8261-0233	8261-0542	8261-1233	8261-2233	8261-0795
8221-0234	8261-0234	8261-0543	8261-1234	8261-2234	8261-0796
8221-0235	8261-0235	8261-0544	8261-1235	8261-2235	8261-0797
8221-0236	8261-0236	8261-0545	8261-1236	8261-2236	8261-0798
8221-0237	8261-0237	8261-0546	8261-1237	8261-2237	8261-0799
8221-0238	8261-0238	8261-0547	8261-1238	8261-2238	8261-0800
8221-0239	8261-0239	8261-0548	8261-1239	8261-2239	8261-0801
8221-0240	8261-0240	8261-0549	8261-1240	8261-2240	8261-0802
8221-0241	8261-0241	8261-0550	8261-1241	8261-2241	8261-0803
8221-0242	8261-0242	8261-0551	8261-1242	8261-2242	8261-0804
8221-0243	8261-0243	8261-0552	8261-1243	8261-2243	8261-0805
8221-0244	8261-0244	8261-0553	8261-1244	8261-2244	8261-0806
8221-0245	8261-0245	8261-0554	8261-1245	8261-2245	8261-0807
8221-0246	8261-0246	8261-0555	8261-1246	8261-2246	8261-0808
8221-0247	8261-0247	8261-0556	8261-1247	8261-2247	8261-0809
8221-0248	8261-0248	8261-0557	8261-1248	8261-2248	8261-0810
8221-0249	8261-0249	8261-0558	8261-1249	8261-2249	8261-0811
8221-0250	8261-0250	8261-0559	8261-1250	8261-2250	8261-0812
8221-0251	8261-0251	8261-0560	8261-1251	8261-2251	8261-0813
8221-0252	8261-0252	8261-0561	8261-1252	8261-2252	8261-0814
8221-0253	8261-0253	8261-0562	8261-1253	8261-2253	8261-0815

Примечание. Допускается применение ручек исполнения 2 по ГОСТ
 Пример условного обозначения пробки ПР для
 лем допуска 6Н:

Пробка 8221-0045

То же, с левой резьбой:

Пробка 8221-0045 6Н

Продолжение табл. 1

в мм		Применяемость						L			Масса, кг. не более		Дет. 1. Вспомогательная (1 шт.)	Дет. 2. Ручка ГОСТ 14748 (1 шт.)			
пробок	калибры	ПР	У-ПР	КПР-ПР	У-НЕ	КНЕ-НЕ	КНЕ-ПР	КИ-НЕ	d	p	D	ПР, У-ПР; КПР-ПР			У-НЕ; КНЕ-НЕ; КНЕ-ПР; КИ-НЕ	ПР, У-ПР; КПР-ПР	У-НЕ; КНЕ-НЕ; КНЕ-ПР; КИ-НЕ
	КИ-НЕ															Обозначение деталей	
8261-3231									80	1,5	132	124		1,62	1,17	Обозначение дет. 1 см. табл. 2	8054 0019
8261-3232										1,0	130	123		1,37	1,09		
8261-3233									82	2,0	135	125		1,62	1,17		
8261-3234										6,0	166	140		3,17	1,94		
8261-3235										4,0	148	130		2,37	1,45		
8261-3236									85	3,0	140	126		1,94			
8261-3237										2,0	135	125		1,70	1,25		
8261-3238										1,5	132	125					
8261-3239										6,0	170	140		3,76	2,12		
8261-3240										4,0	150	132		2,67	1,68		
8261-3241									90	3,0	142	128		2,23			
8261-3242										2,0	138	126	32	2,02	1,46		
8261-3243										1,5	135	125					
8261-3244										6,0	173	140		4,44	2,31		
8261-3245										4,0	150	132		2,90	1,82		
8261-3246									95	3,0	142	128		2,43			
8261-3247										2,0	138	126		2,19	1,57		
8261-3248										1,5	135	125					
8261-3249										6,0	173	140		4,88	2,51		
8261-3250										4,0	150	132		3,18	1,96		
8261-3251									100	3,0	142	128		2,64			
8261-3252										2,0	138	126			1,69		
8261-3253										1,5	135	125		2,38			

контроль для резьбового отверстия с правой резьбой $M10 \times 1,25$ с по-
6Н ГОСТ 17756—72

1 Н ГОСТ 17756—72

3. Конструкция и основные размеры вставок ПР, У—ПР, КПР—ПР, У—НЕ, КНЕ—НЕ, КНЕ—ПР, КИ—НЕ (деталь 1) должны соответствовать указанным на черт. 2, 3 и в табл. 2.

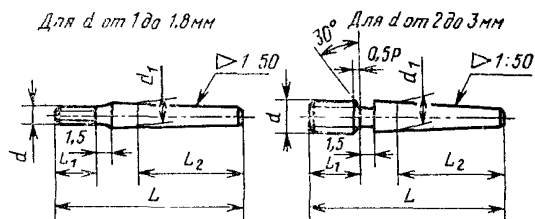

Черт. 2

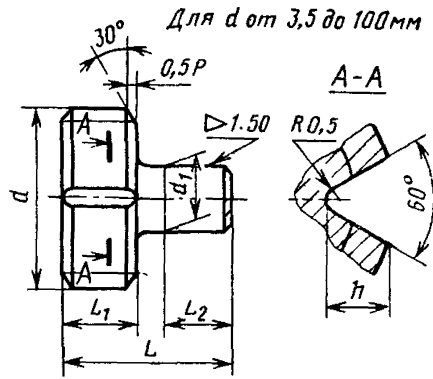

Черт. 3

Примечание. Для вставок с шагом резьбы 1 мм и более вместо фасок $0,5P \times 30^\circ$ должны быть срезаны заходные и выходны витки.

<i>ПР</i>	<i>У—ПР</i>	<i>КПР—ПР</i>	<i>У—НЕ</i>	<i>КНЕ—НЕ</i>	<i>КНЕ—ПР</i>
8221-0001/1	8261-0001/1	8261-0310/1	—	—	—
8221-0002/1	8261-0002/1	8261-0311/1	—	—	—
8221-0003/1	8261-0003/1	8261-0312/1	—	—	—
8221-0004/1	8261-0004/1	8261-0313/1	—	—	—
8221-0005/1	8261-0005/1	8261-0314/1	—	—	—
8221-0006/1	8261-0006/1	8261-0315/1	—	—	—
8221-0007/1	8261-0007/1	8261-0316/1	—	—	—
8221-0008/1	8261-0008/1	8261-0317/1	—	—	—
8221-0009/1	8261-0009/1	8261-0318/1	—	—	—
8221-0010/1	8261-0010/1	8261-0319/1	—	—	—
8221-0011/1	8261-0011/1	8261-0320/1	—	—	—
8221-0012/1	8261-0012/1	8261-0321/1	—	—	—
8221-0013/1	8261-0013/1	8261-0322/1	8261-1013/1	8261-2013/1	8261-0575/1
8221-0014/1	8261-0014/1	8261-0323/1	—	—	—
8221-0015/1	8261-0015/1	8261-0324/1	8261-1015/1	8261-2015/1	8261-0577/1
8221-0016/1	8261-0016/1	8261-0325/1	—	—	—
8221-0017/1	8261-0017/1	8261-0326/1	8261-1017/1	8261-2017/1	8261-0579/1
8221-0018/1	8261-0018/1	8261-0327/1	—	—	—
8221-0019/1	8261-0019/1	8261-0328/1	8261-1019/1	8261-2019/1	8261-0581/1
8221-0020/1	8261-0020/1	8261-0329/1	—	—	—
8221-0021/1	8261-0021/1	8261-0330/1	8261-1021/1	8261-2021/1	8261-0583/1
8221-0022/1	8261-0022/1	8261-0331/1	—	—	—
8221-0023/1	8261-0023/1	8261-0332/1	8261-1023/1	8261-2023/1	8261-0585/1
8221-0024/1	8261-0024/1	8261-0333/1	8261-1024/1	8261-2024/1	8261-0586/1
8221-0025/1	8261-0025/1	8261-0334/1	8261-1025/1	8261-2025/1	8261-0587/1
8221-0026/1	8261-0026/1	8261-0335/1	8261-1026/1	8261-2026/1	8261-0588/1
8221-0027/1	8261-0027/1	8261-0336/1	8261-1027/1	8261-2027/1	8261-0589/1
8221-0028/1	8261-0028/1	8261-0337/1	8261-1028/1	8261-2028/1	8261-0590/1
8221-0029/1	8261-0029/1	8261-0338/1	8261-1029/1	8261-2029/1	8261-0591/1
8221-0030/1	8261-0030/1	8261-0339/1	8261-1030/1	8261-2030/1	8261-0592/1
8221-0031/1	8261-0031/1	8261-0340/1	8261-1031/1	8261-2031/1	8261-0593/1
8221-0032/1	8261-0032/1	8261-0341/1	8261-1032/1	8261-2032/1	8261-0594/1

В мм

Таблица 2

вставка	d	P	L		L ₁		L ₂	d ₁ (поле допус- ка h9)	h	Масса, кг. не более								
			ПР; У-ПР; КПР-ПР	У-НЕ; КНЕ-НЕ; КНЕ-ПР; КН-НЕ	ПР; У-ПР; КПР-ПР	У-НЕ; КНЕ-НЕ; КНЕ-ПР; КН-НЕ				ПР	ПР; У-ПР; КПР-ПР	У-НЕ; КНЕ-НЕ; КНЕ-ПР						
—	1,0	0,25	19,5	—	4	—	11,5	1,5	0,0007	—								
—	—	0,20																
—	—	0,25																
—	1,1	0,20																
—	—	0,25																
—	—	0,20																
—	1,2	0,20																
—	—	0,30																
—	—	0,20																
—	—	0,35																
—	—	0,20																
—	—	0,35																
—	1,6	0,20																
—	—	0,35																
—	—	0,20																
—	1,8	0,35																
—	—	0,20																
8261-3013/1	2,0	0,40	20,5	18,5	5	3,0	11,5	1,5	0,0008	0,0008	0,0008							
—	—	0,25									—	—	—	—	—	—	—	—
8261-3015/1	2,2	0,45									18,5	3,0	—	—	—	—	—	0,0008
—	—	0,25									—	—	—	—	—	—	—	—
8261-3017/1	2,5	0,45									18,5	3,0	—	—	—	—	—	0,0008
—	—	0,35									—	—	—	—	—	—	—	—
8261-3019/1	3,0	0,50									18,5	3,0	—	—	—	—	—	0,0010
—	—	0,35									—	—	—	—	—	—	—	—
8261-3021/1	3,5	0,60									19,0	3,5	—	—	—	—	0,0010	0,0010
—	—	0,35									—	—	—	—	—	—	—	—
8261-3023/1	4,0	0,70									19,0	3,5	—	—	—	—	—	—
8261-3024/1	—	0,50									—	—	—	—	—	—	—	—
8261-3025/1	4,5	0,75	21,5	19,5	6	4,0	12	4	0,0014	0,0012	0,0035							
8261-3026/1	—	0,50																
8261-3027/1	—	0,80																
8261-3028/1	5,0	0,50	22,0	20,0	6	4,0	—	—	—	—	—							
8261-3029/1	5,5	0,50	24,0	21,0	8	5,0	—	—	—	—	—							
8261-3030/1	6,0	1,00	24,0	21,0	8	5,0	12	4	1,00	0,0040	0,0035							
8261-3031/1	—	0,75	24,0	21,0	8	5,0	—	—	0,75	—	—							
8261-3032/1	—	0,50	22,0	20,0	6	4,0	—	—	—	—	—							

ПР	У—ПР	КПР—ПР	У—НЕ	КНЕ—НЕ	КНЕ—ПР
8221-0033/1	8261-0033/1	8261-0342/1	8261-1033/1	8261-2033/1	8261-0595/1
8221-0034/1	8261-0034/1	8261-0343/1	8261-1034/1	8261-2034/1	8261-0596/1
8221-0035/1	8261-0035/1	8261-0344/1	8261-1035/1	8261-2035/1	8261-0597/1
8221-0036/1	8261-0036/1	8261-0345/1	8261-1036/1	8261-2036/1	8261-0598/1
8221-0037/1	8261-0037/1	8261-0346/1	8261-1037/1	8261-2037/1	8261-0599/1
8221-0038/1	8261-0038/1	8261-0347/1	8261-1038/1	8261-2038/1	8261-0600/1
8221-0039/1	8261-0039/1	8261-0348/1	8261-1039/1	8261-2039/1	8261-0601/1
8221-0040/1	8261-0040/1	8261-6349/1	8261-1040/1	8261-2040/1	8261-0602/1
8221-0041/1	8261-0041/1	8261-0350/1	8261-1041/1	8261-2041/1	8261-0603/1
8221-0042/1	8261-0042/1	8261-0351/1	8261-1042/1	8261-2042/1	8261-0604/1
8221-0043/1	8261-0043/1	8261-0352/1	8261-1043/1	8261-2043/1	8261-0605/1
8221-0044/1	8261-0044/1	8261-0353/1	8261-1044/1	8261-2044/1	8261-0606/1
8221-0045/1	8261-0045/1	8261-0354/1	8261-1045/1	8261-2045/1	8261-0607/1
8221-0046/1	8261-0046/1	8261-0355/1	8261-1046/1	8261-2046/1	8261-0608/1
8221-0047/1	8261-0047/1	8261-0356/1	8261-1047/1	8261-2047/1	8261-0609/1
8221-0048/1	8261-0048/1	8261-0357/1	8261-1048/1	8261-2048/1	8261-0610/1
8221-0049/1	8261-0049/1	8261-0358/1	8261-1049/1	8261-2049/1	8261-0611/1
8221-0050/1	8261-0050/1	8261-0359/1	8261-1050/1	8261-2050/1	8261-0612/1
8221-0051/1	8261-0051/1	8261-0360/1	8261-1051/1	8261-2051/1	8261-0613/1
8221-0052/1	8261-0052/1	8261-0361/1	8261-1052/1	8261-2052/1	8261-0614/1
8221-0053/1	8261-0053/1	8261-0362/1	8261-1053/1	8261-2053/1	8261-0615/1
8221-0054/1	8261-0054/1	8261-0363/1	8261-1054/1	8261-2054/1	8261-0616/1
8221-0055/1	8261-0055/1	8261-0364/1	8261-1055/1	8261-2055/1	8261-0617/1
8221-0056/1	8261-0056/1	8261-0365/1	8261-1056/1	8261-2056/1	8261-0618/1
8221-0057/1	8261-0057/1	8261-0366/1	8261-1057/1	8261-2057/1	8261-0619/1
8221-0058/1	8261-0058/1	8261-0367/1	8261-1058/1	8261-2058/1	8261-0620/1
8221-0059/1	8261-0059/1	8261-0368/1	8261-1059/1	8261-2059/1	8261-0621/1
8221-0060/1	8261-0060/1	8261-0369/1	8261-1060/1	8261-2060/1	8261-0622/1
8221-0061/1	8261-0061/1	8261-0370/1	8261-1061/1	8261-2061/1	8261-0623/1
8221-0062/1	8261-0062/1	8261-0371/1	8261-1062/1	8261-2062/1	8261-0624/1
8221-0063/1	8261-0063/1	8261-0372/1	8261-1063/1	8261-2063/1	8261-0625/1
8221-0064/1	8261-0064/1	8261-0373/1	8261-1064/1	8261-2064/1	8261-0626/1

В ММ

Продолжение табл. 2

ВСТАВКА	d	P	L		L ₁		L ₂	d ₁ (поле допус- ка h ₉)	h	Масса, кг, не более		
			ПР; У-ПР; КПР-ПР	У-HE; КHE-HE; КHE-ПР; KH-HE	ПР; У-ПР; КПР-ПР	У-HE; КHE-HE; КHE-ПР; KH-HE				ПР	ПР; У-ПР; КПР-ПР	У-HE; КHE-HE; КHE-ПР; KH-HE
8261-3033/1	7,0	1,00	24,0	21,0	8	5,0	12	4	1,00	0,0045	0,0035	
8261-3034/1		0,75	24,0	21,0	8	5,0			1,75			
8261-3035/1		0,50	22,0	20,0	6	4,0			—	0,0040		
8261-3036/1	8,0	1,25	26,0	22,0	10	6,0			1,25	0,0065	0,0050	
8261-3037/1		1,00	26,0	21,0	10	5,0			1,00			
8261-3038/1		0,75	24,0	21,0	8	5,0			0,75	0,0055		
8261-3039/1	9,0	0,50	24,0	21,0	8	5,0			—	0,0045	0,0055	
8261-3040/1		1,25	26,0	22,0	10	6,0			1,25	0,0075		
8261-3041/1		1,00	26,0	21,0	10	5,0			1,00			
8261-3042/1	10	0,75	24,0	21,0	8	5,0			0,75	0,0065	0,0045	
8261-3043/1		0,50	24	21	8	5			—			
8261-3044/1		1,50	28	24	12	8			1,50			
8261-3045/1	11	1,25	28	23	12	7	1,25	0,010	0,008			
8261-3046/1		1,00	26	22	10	6	1,00					
8261-3047/1		0,75	24	21	8	5	0,75	0,007	0,006			
8261-3048/1	12	0,50	24	21	8	5	—					
8261-3049/1		1,50	31	27	12	8	1,50	0,014	0,011			
8261-3050/1		1,00	29	25	10	6	1,00					
8261-3051/1	13	0,75	27	24	8	5	0,75	0,011	0,010			
8261-3052/1		0,50	27	24	8	5	—					
8261-3053/1		1,75	34	28	15	9	1,75					
8261-3054/1	14	1,50	33	27	14	8	1,50	0,018	0,013			
8261-3055/1		1,25	31	26	12	7	1,25					
8261-3056/1		1,00	29	25	10	6	1,00					
8261-3057/1	15	1,75	29	24	10	5	0,75	0,015	0,010			
8261-3058/1		0,50	27	24	8	5	—					
8261-3059/1		2,00	35	29	16	10	2,00	0,025	0,018			
8261-3060/1	16	1,50	33	27	14	8	1,50		0,018			
8261-3061/1		1,25	31	26	12	7	1,25	0,023	0,016			
8261-3062/1		1,00	31	25	12	6	1,00					
8261-3063/1	17	0,75	29	24	10	5	0,75	0,018	0,012			
8261-3064/1		0,50	27	24	8	5	—					

<i>ПР</i>	<i>У—ПР</i>	<i>КПР—ПР</i>	<i>З—НЕ</i>	<i>КНЕ—НЕ</i>	<i>КНЕ—ПР</i>
8221-0065/1	8261-0065/1	8261-0374/1	8261-1065/1	8261-2065/1	8261-0627/1
8221-0066/1	8261-0066/1	8261-0375/1	8261-1066/1	8261-2066/1	8261-0628/1
8221-0067/1	8261-0067/1	8261-0376/1	8261-1067/1	8261-2067/1	8261-0629/1
8221-0068/1	8261-0068/1	8261-0377/1	8261-1068/1	8261-2068/1	8261-0630/1
8221-0069/1	8261-0069/1	8261-0378/1	8261-1069/1	8261-2069/1	8261-0631/1
8221-0070/1	8261-0070/1	8261-0379/1	8261-1070/1	8261-2070/1	8261-0632/1
8221-0071/1	8261-0071/1	8261-0380/1	8261-1071/1	8261-2071/1	8261-0633/1
8221-0072/1	8261-0072/1	8261-0381/1	8261-1072/1	8261-2072/1	8261-0634/1
8221-0073/1	8261-0073/1	8261-0382/1	8261-1073/1	8261-2073/1	8261-0635/1
8221-0074/1	8261-0074/1	8261-0383/1	8261-1074/1	8261-2074/1	8261-0636/1
8221-0075/1	8261-0075/1	8261-0384/1	8261-1075/1	8261-2075,1	8261-0637/1
8221-0076/1	8261-0076/1	8261-0385/1	8261-1076/1	8261-2076/1	8261-0638/1
8221-0077/1	8261-0077/1	8261-0386/1	8261-1077/1	8261-2077/1	8261-0639/1
8221-0078/1	8261-0078/1	8261-0387/1	8261-1078/1	8261-2078/1	8261-0640/1
8221-0079/1	8261-0079/1	8261-0388/1	8261-1079/1	8261-2079/1	8261-0641/1
8221-0080/1	8261-0080/1	8261-0389/1	8261-1080/1	8261-2080/1	8261-0642/1
8221-0081/1	8261-0081/1	8261-0390/1	8261-1081/1	8261-2081/1	8261-0643/1
8221-0082/1	8261-0082/1	8261-0391/1	8261-1082/1	8261-2082/1	8261-0644/1
8221-0083/1	8261-0083/1	8261-0392/1	8261-1083/1	8261-2083/1	8261-0645/1
8221-0084/1	8261-0084/1	8261-0393/1	8261-1084/1	8261-2084/1	8261-0646/1
8221-0085/1	8261-0085/1	8261-0394/1	8261-1085/1	8261-2085/1	8261-0647/1
8221-0086/1	8261-0086/1	8261-0395/1	8261-1086/1	8261-2086/1	8261-0648/1
8221-0087/1	8261-0087/1	8261-0396/1	8261-1087/1	8261-2087/1	8261-0649/1
8221-0088/1	8261-0088/1	8261-0397/1	8261-1088/1	8261-2088/1	8261-0650/1
8221-0089/1	8261-0089/1	8261-0398/1	8261-1089/1	8261-2089/1	8261-0651/1
8221-0090/1	8261-0090/1	8261-0399/1	8261-1090/1	8261-2090/1	8261-0652/1
8221-0091/1	8261-0091/1	8261-0400/1	8261-1091/1	8261-2091/1	8261-0653/1
8221-0092/1	8261-0092/1	8261-0401/1	8261-1092/1	8261-2092/1	8261-0654/1
8221-0093/1	8261-0093/1	8261-0402/1	8261-1093/1	8261-2093/1	8261-0655/1
8221-0094/1	8261-0094/1	8261-0403/1	8261-1094/1	8261-2094/1	8261-0656/1
8221-0095/1	8261-0095/1	8261-0404/1	8261-1095/1	8261-2095/1	8261-0657/1

В ММ

Продолжение табл. 2

вставок	d	P	L		L ₁		L ₂	d ₁ (поле допус- ка h ₉)	h	Масса кг. не более	
			ПР: У—ПР: КПР—ПР	У—НЛ: КНН—НН: КНН—ПР: КН—НН	ПР: У—ПР: КПР—ПР	У—НН: КНН—НН: КНН—ПР: КН—НН				ПР	ПР: У—ПР: КПР—ПР
КИ—НН											
8261-3065/1	15	1,50	35	29	14	8	15	8	1,50	0,030	0,022
8261-3066/1		1,00	33	28	12	7			1,00		
8261-3067/1	16	2,00	37	31	16	10	15	8	2,00	0,038	0,027
8261-3068/1		1,50	35	29	14	8			1,50		
8261-3069/1		1,00	33	28	12	7			1,00		
8261-3070/1		0,75	31	27	10	6			0,75		
8261-3071/1	17	0,50	29	26	8	5	15	8	—	0,026	0,022
8261-3072/1		1,50	35	29	14	8			1,50		
8261-3073/1		1,00	33	28	12	7			1,00		
8261-3074/1	18	2,50	41	33	20	12	15	8	2,50	0,052	0,038
8261-3075/1		2,00	39	31	18	10			2,00		
8261-3076/1		1,50	35	29	14	8			1,50		
8261-3077/1		1,00	33	28	12	7			1,00		
8261-3078/1		0,75	31	27	10	6			0,75		
8261-3079/1		0,50	31	27	10	6			—		
8261-3080/1	20	2,50	43	35	20	12	15	8	2,50	0,073	0,052
8261-3081/1		2,00	41	33	18	10			2,00		
8261-3082/1		1,50	37	31	14	8			1,50		
8261-3083/1		1,00	35	30	12	7			1,00		
8261-3084/1	20	0,75	33	29	10	6	15	8	0,75	0,050	0,035
8261-3085/1		0,50	33	29,0	10	6,0			—		
8261-3086/1		2,50	43	35,0	20	12,0			2,50		
8261-3087/1	22	2,00	41	33,0	18	10,0	15	8	2,00	0,085	0,060
8261-3088/1		1,50	37	31,0	14	8,0			1,50		
8261-3089/1		1,00	35	30,0	12	7,0			1,00		
8261-3090/1		0,75	33	29,0	10	6,0			0,75		
8261-3091/1	24	0,50	33	29,0	10	6,0	15	8	—	0,055	0,040
8261-3092/1		3,00	48	37,0	25	14,0			3,00		
8261-3093/1		2,00	41	33,0	18	10,0			2,00		
8261-3094/1		1,50	39	31,0	16	8,0			1,50		
8261-3095/1	1,00	37	30,5	14	7,5	1,00	0,085	0,055			

<i>ПР</i>	<i>У—ПР</i>	<i>КПР—ПР</i>	<i>У—ПЕ</i>	<i>КНЕ—ПЕ</i>	<i>КНЕ—ПР</i>
8221-0096/1	8261-0096/1	8261-0405/1	8261-1096/1	8261-2096/1	8261-0658/1
8221-0097/1	8261-0097/1	8261-0406/1	8261-1097/1	8261-2097/1	8261-0659/1
8221-0098/1	8261-0098/1	8261-0407/1	8261-1098/1	8261-2098/1	8261-0660/1
8221-0099/1	8261-0099/1	8261-0408/1	8261-1099/1	8261-2099/1	8261-0661/1
8221-0100/1	8261-0100/1	8261-0409/1	8261-1100/1	8261-2100/1	8261-0662/1
8221-0101/1	8261-0101/1	8261-0410/1	8261-1101/1	8261-2101/1	8261-0663/1
8221-0102/1	8261-0102/1	8261-0411/1	8261-1102/1	8261-2102/1	8261-0664/1
8221-0103/1	8261-0103/1	8261-0412/1	8261-1103/1	8261-2103/1	8261-0665/1
8221-0104/1	8261-0104/1	8261-0413/1	8261-1104/1	8261-2104/1	8261-0666/1
8221-0105/1	8261-0105/1	8261-0414/1	8261-1105/1	8261-2105/1	8261-0667/1
8221-0106/1	8261-0106/1	8261-0415/1	8261-1106/1	8261-2106/1	8261-0668/1
8221-0107/1	8261-0107/1	8261-0416/1	8261-1107/1	8261-2107/1	8261-0669/1
8221-0108/1	8261-0108/1	8261-0417/1	8261-1108/1	8261-2108/1	8261-0670/1
8221-0109/1	8261-0109/1	8261-0418/1	8261-1109/1	8261-2109/1	8261-0671/1
8221-0110/1	8261-0110/1	8261-0419/1	8261-1110/1	8261-2110/1	8261-0672/1
8221-0111/1	8261-0111/1	8261-0420/1	8261-1111/1	8261-2111/1	8261-0673/1
8221-0112/1	8261-0112/1	8261-0421/1	8261-1112/1	8261-2112/1	8261-0674/1
8221-0113/1	8261-0113/1	8261-0422/1	8261-1113/1	8261-2113/1	8261-0675/1
8221-0114/1	8261-0114/1	8261-0423/1	8261-1114/1	8261-2114/1	8261-0676/1
8221-0115/1	8261-0115/1	8261-0424/1	8261-1115/1	8261-2115/1	8261-0677/1
8221-0116/1	8261-0116/1	8261-0425/1	8261-1116/1	8261-2116/1	8261-0678/1
8221-0117/1	8261-0117/1	8261-0426/1	8261-1117/1	8261-2117/1	8261-0679/1
8221-0118/1	8261-0118/1	8261-0427/1	8261-1118/1	8261-2118/1	8261-0680/1
8221-0119/1	8261-0119/1	8261-0428/1	8261-1119/1	8261-2119/1	8261-0681/1
8221-0120/1	8261-0120/1	8261-0429/1	8261-1120/1	8261-2120/1	8261-0682/1
8221-0121/1	8261-0121/1	8261-0430/1	8261-1121/1	8261-2121/1	8261-0683/1
8221-0122/1	8261-0122/1	8261-0431/1	8261-1122/1	8261-2122/1	8261-0684/1
8221-0123/1	8261-0123/1	8261-0432/1	8261-1123/1	8261-2123/1	8261-0685/1
8221-0124/1	8261-0124/1	8261-0433/1	8261-1124/1	8261-2124/1	8261-0686/1
8221-0125/1	8261-0125/1	8261-0434/1	8261-1125/1	8261-2125/1	8261-0687/1
8221-0126/1	8261-0126/1	8261-0435/1	8261-1126/1	8261-2126/1	8261-0688/1

В мм

вставка	d	P	L		L ₁		L ₂	d ₁ (поле допус- ка h9)	h	Масса, кг. но бугее	
			ПР: У-ПР КПР-ПР	У-НЕ: КНЕ-НЕ; КНЕ-ПР; КИ-НЕ	У-ПР: КПР-ПР	У-НЕ: КНЕ-НЕ; КНЕ-ПР; КИ-НЕ				ПР	ПР: У-ПР КПР-ПР
8261-3096/1	24	0,75	35	30,0	12	7,0	16	11	0,75	0,085	0,055
8261-3097/1		2,00	45	37,0	18	10,0			2,00	0,117	
8261-3098/1	25	1,50	43	35,0	16	8,0			1,50	0,110	0,080
8261-3099/1		1,00	41	34,5	14	7,5			1,00		
8261-3100/1	26	1,50	43	35,0	16	8,0			1,50	0,115	
8261-3101/1		3,00	52	41,0	25	14,0			3,00	0,165	0,110
8261-3102/1		2,00	45	37,0	18	10,0			2,00	0,132	0,093
8261-3103/1	27	1,50	43	35,0	16	8,0			1,50	0,120	
8261-3104/1		1,00	41	34,5	14	7,5			1,00		0,080
8261-3105/1		0,75	39	34,0	12	7,0	19	15	0,75	0,110	
8261-3106/1		2,00	45	37,0	18	10,0			2,00		
8261-3107/1	28	1,50	43	36,0	16	9,0			1,50	0,135	0,100
8261-3108/1		1,00	41	34,5	14	7,5			1,00	0,115	0,080
8261-3109/1		3,50	55	43,0	28	16,0			3,50		
8261-3110/1		3,00	55	41,0	28	14,0			3,00	0,21	0,14
8261-3111/1	30	2,00	47	39,0	20	12,0			2,00	0,16	0,11
8261-3112/1		1,50	45	36,0	18	9,0			1,50		
8261-3113/1		1,00	43	35,5	16	8,5			1,00		0,09
8261-3114/1		0,75	41	35,0	14	8,0			0,75	0,14	
8261-3115/1	32	2,00	50	42,0	20	12,0			2,00	0,22	0,14
8261-3116/1		1,50	48	39,0	18	9,0			1,50		
8261-3117/1		3,50	58	46,0	28	16,0			3,50		
8261-3118/1		3,00	58	44,0	28	14,0			3,00	0,28	0,19
8261-3119/1	33	2,00	50	42,0	20	12,0			2,00	0,22	0,17
8261-3120/1		1,50	48	39,0	18	9,0			1,50		
8261-3121/1		1,00	46	38,5	16	8,5	21	18	1,00	0,19	0,14
8261-3122/1		0,75	44	38,0	14	8,0			0,75		
8261-3123/1	35	1,50	48	40,5	18	10,5			1,50	0,22	0,17
8261-3124/1		4,00	62	49,0	32	19,0			4,00	0,35	0,22
8261-3125/1	36	3,00	58	44,0	28	14,0			3,00	0,31	0,19
8261-3126/1		2,00	50	41,0	20	11,0			2,00	0,24	0,17

Обозначение

<i>ПР</i>	<i>У—ПР</i>	<i>КПР—ПР</i>	<i>У—НЕ</i>	<i>КНЕ—НЕ</i>	<i>КНЕ—ПР</i>
8221-0127/1	8261-0127/1	8261-0436/1	8261-1127/1	8261-2127/1	8261-0689/1
8221-0128/1	8261-0128/1	8261-0437/1	8261-1128/1	8261-2128/1	8261-0690/1
8221-0129/1	8261-0129/1	8261-0438/1	8261-1129/1	8261-2129/1	8261-0691/1
8221-0130/1	8261-0130/1	8261-0439/1	8261-1130/1	8261-2130/1	8261-0692/1
8221-0131/1	8261-0131/1	8261-0440/1	8261-1131/1	8261-2131/1	8261-0693/1
8221-0132/1	8261-0132/1	8261-0441/1	8261-1132/1	8261-2132/1	8261-0694/1
8221-0133/1	8261-0133/1	8261-0442/1	8261-1133/1	8261-2133/1	8261-0695/1
8221-0134/1	8261-0134/1	8261-0443/1	8261-1134/1	8261-2134/1	8261-0696/1
8221-0135/1	8261-0135/1	8261-0444/1	8261-1135/1	8261-2135/1	8261-0697/1
8221-0136/1	8261-0136/1	8261-0445/1	8261-1136/1	8261-2136/1	8261-0698/1
8221-0137/1	8261-0137/1	8261-0446/1	8261-1137/1	8261-2137/1	8261-0699/1
8221-0138/1	8261-0138/1	8261-0447/1	8261-1138/1	8261-2138/1	8261-0700/1
8221-0139/1	8261-0139/1	8261-0448/1	8261-1139/1	8261-2139/1	8261-0701/1
8221-0140/1	8261-0140/1	8261-0449/1	8261-1140/1	8261-2140/1	8261-0702/1
8221-0141/1	8261-0141/1	8261-0450/1	8261-1141/1	8261-2141/1	8261-0703/1
8221-0142/1	8261-0142/1	8261-0451/1	8261-1142/1	8261-2142/1	8261-0704/1
8221-0143/1	8261-0143/1	8261-0452/1	8261-1143/1	8261-2143/1	8261-0705/1
8221-0144/1	8261-0144/1	8261-0453/1	8261-1144/1	8261-2144/1	8261-0706/1
8221-0145/1	8261-0145/1	8261-0454/1	8261-1145/1	8261-2145/1	8261-0707/1
8221-0146/1	8261-0146/1	8261-0455/1	8261-1146/1	8261-2146/1	8261-0708/1
8221-0147/1	8261-0147/1	8261-0456/1	8261-1147/1	8261-2147/1	8261-0709/1
8221-0148/1	8261-0148/1	8261-0457/1	8261-1148/1	8261-2148/1	8261-0710/1
8221-0149/1	8261-0149/1	8261-0458/1	8261-1149/1	8261-2149/1	8261-0711/1
8221-0150/1	8261-0150/1	8261-0459/1	8261-1150/1	8261-2150/1	8261-0712/1
8221-0151/1	8261-0151/1	8261-0460/1	8261-1151/1	8261-2151/1	8261-0713/1
8221-0152/1	8261-0152/1	8261-0461/1	8261-1152/1	8261-2152/1	8261-0714/1
8221-0153/1	8261-0153/1	8261-0462/1	8261-1153/1	8261-2153/1	8261-0715/1
8221-0154/1	8261-0154/1	8261-0463/1	8261-1154/1	8261-2154/1	8261-0716/1
8221-0155/1	8261-0155/1	8261-0464/1	8261-1155/1	8261-2155/1	8261-0717/1
8221-0156/1	8261-0156/1	8261-0465/1	8261-1156/1	8261-2156/1	8261-0718/1
8221-0157/1	8261-0157/1	8261-0466/1	8261-1157/1	8261-2157/1	8261-0719/1
8221-0158/1	8261-0158/1	8261-0467/1	8261-1158/1	8261-2158/1	8261-0720/1

Продолжение табл. 2

ВСТАВОК	d	P	L		L ₁		L ₂	d ₁ (полюс допус- ка h ₉)	h	Масса, кг, не более	
			ПР: У-ПР: КПР-ПР	У-HE: КHE-HE: КHE-ПР: КИ-HE	ПР: У-ПР: КПР-ПР	У-HE: КHE-HE: КHE-ПР: КИ-HE				ПР	ПР: У-ПР: КПР-ПР
8261-3127/1	36	1,50	48	40,5	18	10,5	21	18	1,5	0,23	0,16
8261-3128/1		1,00	40	40,0	16	10,0			1,0		
8261-3129/1	38	1,50	48	40,5	18	10,5			1,5	0,24	0,17
8261-3130/1		4,00	62	49,0	32	19,0			4,0	0,40	0,27
8261-3131/1	39	3,0	58	44,0	28	14,0			3,0	0,5	0,21
8261-3132/1		2,0	50	41,0	20	11,0			2,0		
8261-3133/1	40	1,5	48	40,5	18	10,5			1,5	0,28	0,18
8261-3134/1		1,0	46	40,0	16	10,0			1,0		
8261-3135/1	40	3,0	58	44,0	28	14,0			3,0	0,38	
8261-3136/1		2,0	50	42,0	20	12,0			2,0		0,22
8261-3137/1	42	1,5	48	41,0	18	11,0			1,5	0,29	
8261-3138/1		4,5	72	55,0	38	21,0			4,5		
8261-3139/1	42	4,0	70	52,0	36	18,0	4,0	0,55	0,35		
8261-3140/1		3,0	62	48,0	28	14,0	3,0	0,44	0,30		
8261-3141/1	45	2,0	56	46,0	22	12,0	2,0				
8261-3142/1		1,5	54	45,0	20	11,0	1,5	0,36	0,26		
8261-3143/1	45	1,0	52	44,0	18	10,0	1,0				
8261-3144/1		4,5	72	55,0	38	21,0	4,5				
8261-3145/1	45	4,0	70	52,0	36	18,0	4,0	0,62	0,38		
8261-3146/1		3,0	62	49,0	28	15,0	3,0	0,48	0,31		
8261-3147/1	48	2,0	56	46,0	22	12,0	2,0				
8261-3148/1		1,5	54	45,0	20	11,0	1,5	0,40	0,27		
8261-3149/1	48	1,0	52	44,0	18	10,0	1,0	0,36	0,24		
8261-3150/1		5,0	76	59,0	42	25,0	5,0	0,76	0,46		
8261-3151/1	50	4,0	70	54,0	36	20,0	4,0	0,65	0,39		
8261-3152/1		3,0	62	49,0	28	15,0	3,0	0,54	0,33		
8261-3153/1	48	2,0	56	46,0	22	12,0	2,0				
8261-3154/1		1,5	54	45,0	20	11,0	1,5	0,44	0,29		
8261-3155/1	50	1,0	52	44,0	18	10,0	1,0				
8261-3156/1		3,0	62	49,0	28	15,0	3,0	0,57	0,35		
8261-3157/1	50	2,0	56	46,0	22	12,0	2,0	0,47	0,29		
8261-3158/1		1,5	54	45,0	20	11,0	1,5				

Обозначение

<i>ПР</i>	<i>У—ПР</i>	<i>КПР—ПР</i>	<i>У—НЕ</i>	<i>КНЕ—НЕ</i>	<i>КНЕ—ПР</i>
8221-0159/1	8261-0159/1	8261-0468/1	8261-1159/1	8261-2159/1	8261-0721/1
8221-0160/1	8261-0160/1	8261-0469/1	8261-1160/1	8261-2160/1	8261-0722/1
8221-0161/1	8261-0161/1	8261-0470/1	8261-1161/1	8261-2161/1	8261-0723/1
8221-0162/1	8261-0162/1	8261-0471/1	8261-1162/1	8261-2162/1	8261-0724/1
8221-0163/1	8261-0163/1	8261-0472/1	8261-1163/1	8261-2163/1	8261-0725/1
8221-0164/1	8261-0164/1	8261-0473/1	8261-1164/1	8261-2164/1	8261-0726/1
8221-0165/1	8261-0165/1	8261-0474/1	8261-1165/1	8261-2165/1	8261-0727/1
8221-0166/1	8261-0166/1	8261-0475/1	8261-1166/1	8261-2166/1	8261-0728/1
8221-0167/1	8261-0167/1	8261-0476/1	8261-1167/1	8261-2167/1	8261-0729/1
8221-0168/1	8261-0168/1	8261-0477/1	8261-1168/1	8261-2168/1	8261-0730/1
8221-0169/1	8261-0169/1	8261-0478/1	8261-1169/1	8261-2169/1	8261-0731/1
8221-0170/1	8261-0170/1	8261-0479/1	8261-1170/1	8261-2170/1	8261-0732/1
8221-0171/1	8261-0171/1	8261-0480/1	8261-1171/1	8261-2171/1	8261-0733/1
8221-0172/1	8261-0172/1	8261-0481/1	8261-1172/1	8261-2172/1	8261-0734/1
8221-0173/1	8261-0173/1	8261-0482/1	8261-1173/1	8261-2173/1	8261-0735/1
8221-0174/1	8261-0174/1	8261-0483/1	8261-1174/1	8261-2174/1	8261-0736/1
8221-0175/1	8261-0175/1	8261-0484/1	8261-1175/1	8261-2175/1	8261-0737/1
8221-0176/1	8261-0176/1	8261-0485/1	8261-1176/1	8261-2176/1	8261-0738/1
8221-0177/1	8261-0177/1	8261-0486/1	8261-1177/1	8261-2177/1	8261-0739/1
8221-0178/1	8261-0178/1	8261-0487/1	8261-1178/1	8261-2178/1	8261-0740/1
8221-0179/1	8261-0179/1	8261-0488/1	8261-1179/1	8261-2179/1	8261-0741/1
8221-0180/1	8261-0180/1	8261-0489/1	8261-1180/1	8261-2180/1	8261-0742/1
8221-0181/1	8261-0181/1	8261-0490/1	8261-1181/1	8261-2181/1	8261-0743/1
8221-0182/1	8261-0182/1	8261-0491/1	8261-1182/1	8261-2182/1	8261-0744/1
8221-0183/1	8261-0183/1	8261-0492/1	8261-1183/1	8261-2183/1	8261-0745/1
8221-0184/1	8261-0184/1	8261-0493/1	8261-1184/1	8261-2184/1	8261-0746/1
8221-0185/1	8261-0185/1	8261-0494/1	8261-1185/1	8261-2185/1	8261-0747/1
8221-0186/1	8261-0186/1	8261-0495/1	8261-1186/1	8261-2186/1	8261-0748/1
8221-0187/1	8261-0187/1	8261-0496/1	8261-1187/1	8261-2187/1	8261-0749/1
8221-0188/1	8261-0188/1	8261-0497/1	8261-1188/1	8261-2188/1	8261-0750/1
8221-0189/1	8261-0189/1	8261-0498/1	8261-1189/1	8261-2189/1	8261-0751/1
8221-0190/1	8261-0190/1	8261-0499/1	8261-1190/1	8261-2190/1	8261-0752/1

В ММ

ВСТАВОК	d	P	L			L ₁		L ₂	d ₁ (поле допус- ка h ₉)	h	Масса, кг, не более		
			ПР; У-ПР; КПР-ПР	У-НЕ; КНЕ-НЕ; КНЕ-ПР; КИ-НЕ	У-НЕ; КНЕ-НЕ; КНЕ-ПР; КИ-НЕ	ПР; У-ПР; КПР-ПР	У-НЕ; КНЕ-НЕ; КНЕ-ПР; КИ-НЕ				ПР	ПР; У-ПР; КПР-ПР	У-НЕ; КНЕ-НЕ; КНЕ-ПР; КИ-НЕ
8261-3159/1	52	5,0	76	59,0	42	25,0	24	21	5,0	0,87	0,53		
8261-3160/1		4,0	70	54,0	36	20,0			4,0	0,74	0,46		
8261-3161/1		3,0	62	49,0	28	15,0			3,0	0,62			
8261-3162/1		2,0	56	46,0	22	12,0			2,0		0,37		
8261-3163/1		1,5	54	45,0	20	11,0			1,5	0,50			
8261-3164/1		1,0	52	44,0	18	10,0			1,0				
8261-3165/1	55	4,0	70	54,0	36	20,0			4,0	0,83	0,51		
8261-3166/1		3,0	62	49,0	28	15,0			3,0	0,67			
8261-3167/1		2,0	56	48,0	22	14,0			2,0		0,41		
8261-3168/1		1,5	54	47,0	20	13,0			1,5	0,55			
8261-3169/1		5,5	84	62	50	28			5,5	1,15	0,69		
8261-3170/1		4,0	70	54	36	20			4,0	0,84	0,51		
8261-3171/1	56	3,0	62	49	28	15			3,0	0,69			
8261-3172/1		2,0	56	48	22	14			2,0		0,42		
8261-3173/1		1,5	54	47	20	13			1,5	0,57			
8261-3174/1		1,0	52	46	18	12			1,0	0,52	0,38		
8261-3175/1	58	4,0	70	54	36	20			4,0	0,91	0,55		
8261-3176/1		3,0	62	49	28	15			3,0	0,74			
8261-3177/1		2,0	56	48	22	14			2,0		0,44		
8261-3178/1		1,5	54	47	20	13			1,5	0,62			
8261-3179/1		5,5	84	62	50	28			5,5	1,32	0,77		
8261-3180/1		4,0	70	54	36	20			4,0	0,97	0,58		
8261-3181/1	60	3,0	62	49	28	15			3,0	0,78			
8261-3182/1		2,0	56	48	22	14			2,0		0,44		
8261-3183/1		1,5	54	47	20	13	1,5	0,64					
8261-3184/1		1,0	52	46	18	12	1,0	0,54	0,40				
8261-3185/1	62	4,0	70	54	36	20	4,0	1,02	0,61				
8261-3186/1		3,0	62	49	28	15	3,0	0,82					
8261-3187/1		2,0	59	48	25	14	2,0		0,51				
8261-3188/1		1,5	56	47	22	13	1,5	0,75					
8261-3189/1	64	6,0	90	64	56	30	6,0	1,65	0,88				
8261-3190/1		4,0	70	54	36	20	4,0	1,07	0,65				

ПР	У—ПР	КПР—ПР	У—НЕ	КНЕ—НЕ	КНЕ—ПР
8221-0191/1	8261-0191/1	8261-0500/1	8261-1191/1	8261-2191/1	8261-0753/1
8221-0192/1	8261-0192/1	8261-0501/1	8261-1192/1	8261-2192/1	8261-0754/1
8221-0193/1	8261-0193/1	8261-0502/1	8261-1193/1	8261-2193/1	8261-0755/1
8221-0194/1	8261-0194/1	8261-0503/1	8261-1194/1	8261-2194/1	8261-0756/1
8221-0195/1	8261-0195/1	8261-0504/1	8261-1195/1	8261-2195/1	8261-0757/1
8221-0196/1	8261-0196/1	8261-0505/1	8261-1196/1	8261-2196/1	8261-0758/1
8221-0197/1	8261-0197/1	8261-0506/1	8261-1197/1	8261-2197/1	8261-0759/1
8221-0198/1	8261-0198/1	8261-0507/1	8261-1198/1	8261-2198/1	8261-0760/1
8221-0199/1	8261-0199/1	8261-0508/1	8261-1199/1	8261-2199/1	8261-0761/1
8221-0200/1	8261-0200/1	8261-0509/1	8261-1200/1	8261-2200/1	8261-0762/1
8221-0201/1	8261-0201/1	8261-0510/1	8261-1201/1	8261-2201/1	8261-0763/1
8221-0202/1	8261-0202/1	8261-0511/1	8261-1202/1	8261-2202/1	8261-0764/1
8221-0203/1	8261-0203/1	8261-0512/1	8261-1203/1	8261-2203/1	8261-0765/1
8221-0204/1	8261-0204/1	8261-0513/1	8261-1204/1	8261-2204/1	8261-0766/1
8221-0205/1	8261-0205/1	8261-0514/1	8261-1205/1	8261-2205/1	8261-0767/1
8221-0206/1	8261-0206/1	8261-0515/1	8261-1206/1	8261-2206/1	8261-0768/1
8221-0207/1	8261-0207/1	8261-0516/1	8261-1207/1	8261-2207/1	8261-0769/1
8221-0208/1	8261-0208/1	8261-0517/1	8261-1208/1	8261-2208/1	8261-0770/1
8221-0209/1	8261-0209/1	8261-0518/1	8261-1209/1	8261-2209/1	8261-0771/1
8221-0210/1	8261-0210/1	8261-0519/1	8261-1210/1	8261-2210/1	8261-0772/1
8221-0211/1	8261-0211/1	8261-0520/1	8261-1211/1	8261-2211/1	8261-0773/1
8221-0212/1	8261-0212/1	8261-0521/1	8261-1212/1	8261-2212/1	8261-0774/1
8221-0213/1	8261-0213/1	8261-0522/1	8261-1213/1	8261-2213/1	8261-0775/1
8221-0214/1	8261-0214/1	8261-0523/1	8261-1214/1	8261-2214/1	8261-0776/1
8221-0215/1	8261-0215/1	8261-0524/1	8261-1215/1	8261-2215/1	8261-0777/1
8221-0216/1	8261-0216/1	8261-0525/1	8261-1216/1	8261-2216/1	8261-0778/1
8221-0217/1	8261-0217/1	8261-0526/1	8261-1217/1	8261-2217/1	8261-0779/1
8221-0218/1	8261-0218/1	8261-0527/1	8261-1218/1	8261-2218/1	8261-0780/1
8221-0219/1	8261-0219/1	8261-0528/1	8261-1219/1	8261-2219/1	8261-0781/1
8221-0220/1	8261-0220/1	8261-0529/1	8261-1220/1	8261-2220/1	8261-0782/1
8221-0221/1	8261-0221/1	8261-0530/1	8261-1221/1	8261-2221/1	8261-0783/1
8221-0222/1	8261-0222/1	8261-0531/1	8261-1222/1	8261-2222/1	8261-0784/1

В ММ

ВСТАВОК	d	P	L		L ₁		L ₂	d ₁ (поле допус- ка №9)	h	Масса, кг. не более	
			ПР; У-ПР; КПР-ПР	У-НЕ; КНЕ-НЕ; КНЕ-ПР; КН-НЕ	ПР; У-ПР; КПР-ПР	У-НЕ; КНЕ-НЕ; КНЕ-ПР; КН-НЕ				ПР	ПР У-ПР; КПР-ПР
8261-3191/1	64	3,0	62	49	28	15	24	21	3,0	0,88	0,52
8261-3192/1		2,0	59	48	25	14			2,0	0,80	
8261-3193/1		1,5	56	47	22	13			1,5	0,71	
8261-3194/1		1,0	52	46	18	12			1,0		
8261-3195/1	65	4,0	70	54	36	20			4,0	1,10	0,67
8261-3196/1		3,0	62	49	28	15			3,0	0,90	0,56
8261-3197/1		2,0	59	48	25	14			2,0	0,82	
8261-3198/1		1,5	56	47	22	13			1,5		
8261-3199/1	68	6,0	90	64	56	30			6,0	1,82	1,03
8261-3200/1		4,0	70	54	36	20			4,0	1,22	0,72
8261-3201/1		3,0	62	49	28	15			3,0	0,98	0,57
8261-3202/1		2,0	59	48	25	14			2,0	0,88	0,52
8261-3203/1	1,5	56	47	22	13	1,5	0,79				
8261-3204/1	70	1,0	52	46	18	12	1,0		1,09		
8261-3205/1		6,0	90	64	56	30	6,0	1,96			
8261-3206/1		4,0	72	54	38	20	4,0	1,36	0,77		
8261-3207/1		3,0	64	50	30	16	3,0	1,09	0,64		
8261-3208/1	2,0	59	49	25	15	2,0	0,93				
8261-3209/1	72	1,5	56	48	22	14	1,5		1,21		
8261-3210/1		6,0	96	70	56	30	6,0	2,09			
8261-3211/1		4,0	78	60	38	20	4,0	1,48	0,86		
8261-3212/1		3,0	70	56	30	16	3,0	1,21	0,72		
8261-3213/1	2,0	65	55	25	15	2,0	1,03				
8261-3214/1	75	1,5	62	54	22	14	1,5		0,92		
8261-3215/1		1,0	60	53	20	13	1,0	0,86			
8261-3216/1		4,0	78	60	38	20	4,0	1,60			
8261-3217/1		3,0	70	56	30	16	3,0	1,29	0,77		
8261-3218/1	2,0	65	55	25	15	2,0	1,10				
8261-3219/1	76	1,5	62	54	22	14	1,5		1,32		
8261-3220/1		6,0	96	70	56	30	6,0	2,34			
8261-3221/1		4,0	78	60	38	20	4,0	1,63	0,94		
8261-3222/1		3,0	70	56	30	16	3,0	1,33	0,78		

ПР	У—ПР	КПР—ПР	У—НЕ	КНЕ—НЕ	КНЕ—ПР
8221-0223/1	8261-0223/1	8261-0532/1	8261-1223/1	8261-2223/1	8261-0785/1
8221-0224/1	8261-0224/1	8261-0533/1	8261-1224/1	8261-2224/1	8261-0786/1
8221-0225/1	8261-0225/1	8261-0534/1	8261-1225/1	8261-2225/1	8261-0787/1
8221-0226/1	8261-0226/1	8261-0535/1	8261-1226/1	8261-2226/1	8261-0788/1
8221-0227/1	8261-0227/1	8261-0536/1	8261-1227/1	8261-2227/1	8261-0789/1
8221-0228/1	8261-0228/1	8261-0537/1	8261-1228/1	8261-2228/1	8261-0790/1
8221-0229/1	8261-0229/1	8261-0538/1	8261-1229/1	8261-2229/1	8261-0791/1
8221-0230/1	8261-0230/1	8261-0539/1	8261-1230/1	8261-2230/1	8261-0792/1
8221-0231/1	8261-0231/1	8261-0540/1	8261-1231/1	8261-2231/1	8261-0793/1
8221-0232/1	8261-0232/1	8261-0541/1	8261-1232/1	8261-2232/1	8261-0794/1
8221-0233/1	8261-0233/1	8261-0542/1	8261-1233/1	8261-2233/1	8261-0795/1
8221-0234/1	8261-0234/1	8261-0543/1	8261-1234/1	8261-2234/1	8261-0796/1
8221-0235/1	8261-0235/1	8261-0544/1	8261-1235/1	8261-2235/1	8261-0797/1
8221-0236/1	8261-0236/1	8261-0545/1	8261-1236/1	8261-2236/1	8261-0798/1
8221-0237/1	8261-0237/1	8261-0546/1	8261-1237/1	8261-2237/1	8261-0799/1
8221-0238/1	8261-0238/1	8261-0547/1	8261-1238/1	8261-2238/1	8261-0800/1
8221-0239/1	8261-0239/1	8261-0548/1	8261-1239/1	8261-2239/1	8261-0801/1
8221-0240/1	8261-0240/1	8261-0549/1	8261-1240/1	8261-2240/1	8261-0802/1
8221-0241/1	8261-0241/1	8261-0550/1	8261-1241/1	8261-2241/1	8261-0803/1
8221-0242/1	8261-0242/1	8261-0551/1	8261-1242/1	8261-2242/1	8261-0804/1
8221-0243/1	8261-0243/1	8261-0552/1	8261-1243/1	8261-2243/1	8261-0805/1
8221-0244/1	8261-0244/1	8261-0553/1	8261-1244/1	8261-2244/1	8261-0806/1
8221-0245/1	8261-0245/1	8261-0554/1	8261-1245/1	8261-2245/1	8261-0807/1
8221-0246/1	8261-0246/1	8261-0555/1	8261-1246/1	8261-2246/1	8261-0808/1
8221-0247/1	8261-0247/1	8261-0556/1	8261-1247/1	8261-2247/1	8261-0809/1
8221-0248/1	8261-0248/1	8261-0557/1	8261-1248/1	8261-2248/1	8261-0810/1
8221-0249/1	8261-0249/1	8261-0558/1	8261-1249/1	8261-2249/1	8261-0811/1
8221-0250/1	8261-0250/1	8261-0559/1	8261-1250/1	8261-2250/1	8261-0812/1
8221-0251/1	8261-0251/1	8261-0560/1	8261-1251/1	8261-2251/1	8261-0813/1
8221-0252/1	8261-0252/1	8261-0561/1	8261-1252/1	8261-2252/1	8261-0814/1
8221-0253/1	8261-0253/1	8261-0562/1	8261-1253/1	8261-2253/1	8261-0815/1

В ММ

вставка	d	P	L		L ₁		L ₂	d ₁ (поле допус- ка Б9)	h	Масса, кг, не более	
			ПР: У-ПР: КПР-ПР	У-НЕ: КНЕ-НЕ: КНЕ-ПР: КИ-НЕ	ПР: У-ПР: КПР-ПР	У-НЕ: КНЕ-НЕ: КНЕ-ПР: КИ-НЕ				ПР	ПР: У-ПР: КПР-ПР
8261-3223/1	76	2,0	65	55	25	15	30	24	2,0	1,13	0,78
8261-3224/1		1,5	62	54	22	14			1,5		
8261-3225/1	78	1,0	60	53	20	13			1,0	0,95	0,78
8261-3226/1		2,0	65	55	25	15			2,0	1,18	0,78
8261-3227/1	80	6,0	96	70	56	30			6,0	2,54	1,45
8261-3228/1		4,0	78	60	38	20			4,0	1,80	1,02
8261-3229/1	80	3,0	70	56	30	16			3,0	1,45	0,85
8261-3230/1		2,0	65	55	25	15			2,0	1,30	
8261-3231/1	82	1,5	62	54	22	14			1,5		
8261-3232/1		1,0	60	53	20	13			1,0	1,05	0,77
8261-3233/1	85	2,0	65	55	25	15			2,0	1,30	0,85
8261-3234/1		6,0	96	70	56	30			6,0	2,85	1,62
8261-3235/1	85	4,0	78	60	38	20			4,0	2,05	1,13
8261-3236/1		3,0	70	56	30	16			3,0	1,62	0,93
8261-3237/1	90	2,0	65	55	25	15			2,0	1,38	
8261-3238/1		1,5	62	55	22	15			1,5		
8261-3239/1	90	6,0	100	70	60	30			6,0	3,44	1,80
8261-3240/1		4,0	80	62	40	22			4,0	2,35	1,36
8261-3241/1	95	3,0	72	58	32	18			3,0	1,91	1,14
8261-3242/1		2,0	68	56	28	16			2,0	1,70	
8261-3243/1	95	1,5	65	55	25	15	1,5				
8261-3244/1		6,0	103	70	63	30	6,0	4,12	1,99		
8261-3245/1	100	4,0	80	62	40	22	4,0	2,58	1,50		
8261-3246/1		3,0	72	58	32	18	3,0	2,11	1,25		
8261-3247/1	100	2,0	68	56	28	16	2,0	1,87			
8261-3248/1		1,5	65	55	25	15	1,5				
8261-3249/1	100	6,0	103	70	63	30	6,0	4,56	2,19		
8261-3250/1		4,0	80	62	40	22	4,0	2,86	1,64		
8261-3251/1	100	3,0	72	58	32	18	3,0	2,32	1,37		
8261-3252/1		2,0	68	56	28	16	2,0	2,06			
8261-3253/1		1,5	65	55	25	15	1,5				

Пример условного обозначения проходной вставки *ПР* для контроля резьбового отверстия с правой резьбой $M10 \times 1,25$ с полем допуска 6H:

Вставка 8221-0045/1 6H ГОСТ 17756—72

То же, с левой резьбой:

Вставка 8221-0045/1 6H LH ГОСТ 17756—72

2, 3. (Измененная редакция, Изм. № 1, 2, 3).

3а. Исполнительные размеры — по ГОСТ 18465 и ГОСТ 18466. (Введен дополнительно, Изм. № 2).

4. Центровые отверстия — по ГОСТ 14034.

5. Технические требования — по ГОСТ 2016.

6. Размеры, не указанные на черт. 2—3, принимаются по конструктивным и технологическим соображениям.

7. Маркировать по ГОСТ 2016 с добавлением последних четырех знаков обозначения на калибрах с размерами выше 14 мм.

ИНФОРМАЦИОННЫЕ ДАННЫЕ

1. РАЗРАБОТАН И ВНЕСЕН Министерством станкостроительной и инструментальной промышленности СССР

РАЗРАБОТЧИКИ

И. А. Медовой, Г. С. Кудинова

2. УТВЕРЖДЕН И ВВЕДЕН В ДЕЙСТВИЕ Постановлением Государственного комитета СССР по стандартам от 30.05.72 № 1101

3. Срок проверки — 1994 г.,
периодичность проверки — 10 лет

4. ВЗАМЕН МН 564—62

5. ССЫЛОЧНЫЕ НОРМАТИВНО-ТЕХНИЧЕСКИЕ ДОКУМЕНТЫ

Обозначение НТД, на который дана ссылка	Номер пункта
ГОСТ 2016—86	5, 7
ГОСТ 14034—74	4
ГОСТ 14748—69	2
ГОСТ 16093—81	1
ГОСТ 18465—73	3а
ГОСТ 18466—73	3а

6. ПЕРЕИЗДАНИЕ (март 1990 г.) с Изменениями № 1, 2, 3, утвержденными в сентябре 1974 г., ноябре 1983 г., июле 1989 г. (ИУС 10—74, 2—84, 12—89).